

# 1810

## Heavy-Duty Modular Single Cartridge Seal

*Built on Chesterton's AXIUS™ modular platform for simple configuration and installation plant-wide*

This Chesterton® single cartridge seal offers you the ultimate in seal quality, flexibility, and convenience. Leveraging Chesterton's proprietary AXIUS modular platform, the 1810 can be configured with several different face profiles and auxiliary components which allows performance to be tailored to a wide range of process conditions.

A plant-wide sealing solution, the 1810 is effective for both simple and highly demanding applications. It offers selectable features around a common gland housing. This flexibility allows for the creation of the best sealing parameters for your equipment and application needs to maximize single seal reliability.

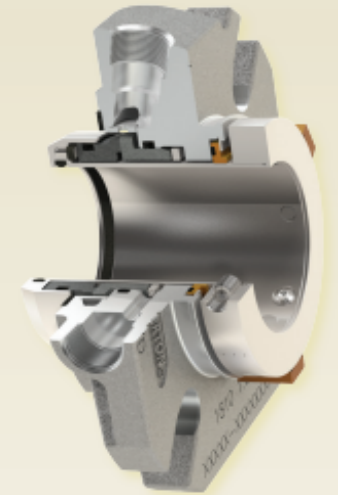
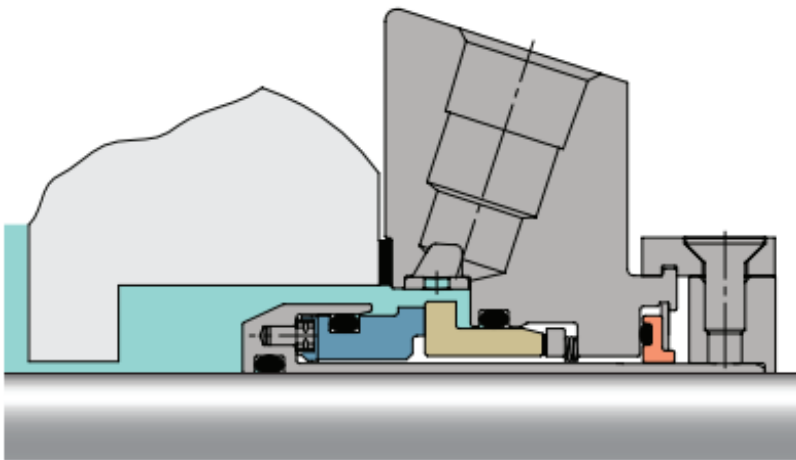

### Advantages

- Simplifies configuration and maximizes seal performance with the AXIUS™ modular platform
- Maintains reliability throughout temperature cycling and stop/start processes with monolithic seal faces
- Increases face life and reduces contact stress with cushioned drive pins
- Allows for easy, positive seal identification with ViewIn™ technology

### SPECIFICATIONS

#### Operating Parameters

Sizes	25 mm – 120 mm 1.00" – 4.75"
Pressure	711 mm or 28" Hg Vacuum to 40 bar g (600 psig*)
Temperature	-55°C – 300°C (-67°F – 570°F) Temperature limits depend on actual elastomers used
Speed	25 m/s (5000 fpm)

#### Applicable Standards and Approvals

ISO-3069C, ASME B73.1, B73.2

\* Seal pressure capabilities are dependent on the fluid sealed, temperature, speed, and seal face combinations. For operation outside the limits and additional materials consult Chesterton Mechanical Seal Engineering.

#### Materials of Construction

Rotary Faces	CB SSC TC
Stationary Faces	SSC TC
Elastomers	FKM EPDM FEPM FFKM
Metal Parts	316 Stainless Steel (EN 1.4401)
Springs	Alloy C-276 (EN 2.4819)

# Dimensional Data

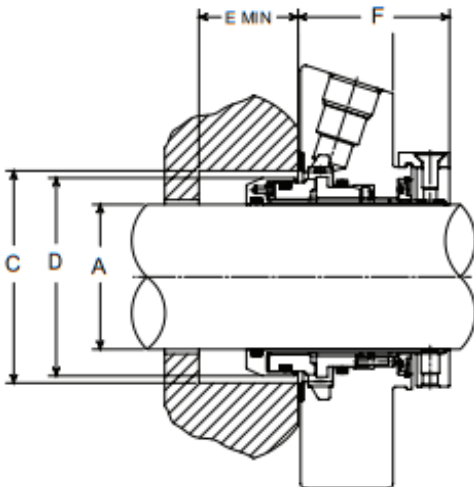
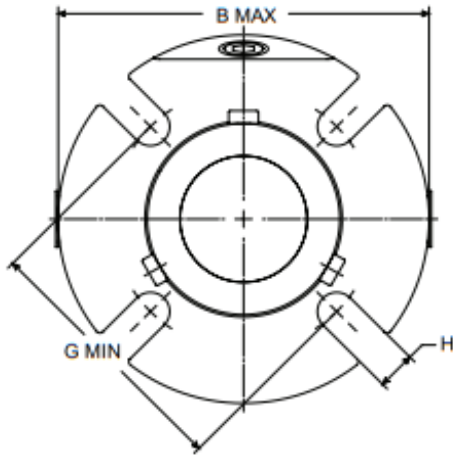

### 1810 KEY

- A – Shaft Size
- B – Maximum Gland Diameter
- C – Seal Chamber Bore
- D – Seal Outside Diameter
- E – Minimum Seal Chamber Depth
- F – Outboard Seal Length
- G – Minimum Bolt Circle by Bolt Size
- H – Slot Width

### 1810 Dimensional Data Metric

SHAFT SIZE	GLAND OD		STUFFING BOX BORE		IB SEAL DIA	SB DEPTH	OB LENGTH	BOLT CIRCLE BY BOLT SIZE			SLOT WIDTH
	B	C	C	D	E	F	G MIN				
A	MAX	MIN	MAX	MAX	MIN	MAX	10 mm	12 mm	16 mm	H	
25	104	44	54	43	19	50	73	-	-	11	
28	104	47	57	46	19	50	76	-	-	11	
30	104	49	59	48	19	50	78	-	-	11	
32	104	51	61	50	19	50	80	-	-	11	
33	114	52	62	51	19	50	81	83	-	14	
35	111	54	64	53	19	50	85	85	-	14	
38	114	57	66	56	19	50	86	88	-	14	
40	127	59	68	58	19	50	90	92	-	13	
42	127	61	68	60	19	50	89	92	-	13	
43	127	62	68	61	19	50	94	96	-	13	
45	139	64	73	63	19	50	95	97	-	13	
48	139	67	73	66	19	50	95	97	-	13	
50	139	69	78	68	19	50	100	102	-	13	
53	152	73	87	72	19	50	109	111	115	17	
55	152	74	83	73	19	50	105	107	119	17	
58	152	80	91	78	19	50	116	118	122	17	
60	152	80	91	78	19	50	116	118	130	17	
65	164	86	101	84	19	50	-	128	132	17	
70	196	96	113	93	24	63	137	141	-	17	
75	202	102	119	99	24	63	143	147	-	17	
80	203	106	122	103	24	63	149	151	-	17	
85	211	111	129	109	24	63	156	159	163	21	
90	214	116	132	113	24	63	160	164	168	21	
95	221	121	138	118	24	63	161	156	169	21	
100	228	127	144	125	24	63	168	172	176	21	
110	237	137	154	134	24	63	178	182	186	21	
120	266	146	163	144	24	63	190	194	197	21	

### 1810 Dimensional Data Inches

SHAFT SIZE	GLAND OD		STUFFING BOX BORE		IB SEAL DIA	SB DEPTH	OB LENGTH	BOLT CIRCLE BY BOLT SIZE			SLOT WIDTH
	B	C	C	D	E	F	G MIN				
A	MAX	MIN	MAX	MAX	MIN	MAX	3/8"	1/2"	5/8"	H	
1.000	4.11	1.75	2.13	1.69	0.73	2.07	2.87	-	-	0.44	
1.250	4.11	1.88	2.26	1.82	0.73	2.07	3.00	-	-	0.44	
1.250	4.11	2.00	2.38	1.94	0.73	2.07	3.12	-	-	0.44	
1.375	4.36	2.13	2.51	2.07	0.73	2.07	3.25	3.37	-	0.57	
1.500	4.49	2.25	2.63	2.19	0.73	2.07	3.38	3.50	-	0.57	
1.625	4.99	2.38	2.69	2.32	0.73	2.07	3.51	3.63	-	0.57	
1.750	5.49	2.50	2.81	2.44	0.73	2.07	3.62	3.75	-	0.57	
1.875	5.49	2.63	2.94	2.57	0.73	2.07	3.75	3.87	-	0.57	
2.000	5.49	2.75	3.19	2.69	0.73	2.07	4.13	4.25	-	0.57	
2.125	5.99	2.88	3.44	2.82	0.73	2.07	4.25	4.38	4.50	0.69	
2.250	5.99	3.00	3.56	2.94	0.73	2.07	4.37	4.50	4.62	0.69	
2.375	5.99	3.13	3.59	3.07	0.73	2.07	4.58	4.71	4.83	0.69	
2.500	6.49	3.25	3.81	3.19	0.73	2.07	4.62	4.75	4.87	0.69	
2.625	6.49	3.38	3.94	3.32	0.73	2.07	5.00	5.12	5.25	0.69	
2.750	7.71	3.75	4.44	3.67	0.96	2.48	5.42	5.55	-	0.69	
2.875	7.83	3.88	4.56	3.79	0.96	2.48	5.50	5.71	-	0.69	
3.000	7.94	4.00	4.69	3.92	0.96	2.48	5.65	5.77	-	0.69	
3.125	7.99	4.13	4.81	4.04	0.96	2.48	5.80	5.92	-	0.69	
3.250	8.19	4.25	4.94	4.17	0.96	2.48	5.93	6.17	-	0.69	
3.375	8.31	4.38	5.06	4.29	0.96	2.48	6.05	6.30	6.39	0.81	
3.500	8.44	4.50	5.19	4.42	0.96	2.48	6.18	6.31	6.43	0.81	
3.625	8.49	4.63	5.31	4.54	0.96	2.48	6.31	6.52	6.62	0.81	
3.750	8.72	4.75	5.44	4.67	0.96	2.48	6.38	6.51	6.63	0.81	
3.875	8.84	4.88	5.56	4.79	0.96	2.48	6.52	6.72	6.82	0.81	
4.000	8.96	5.00	5.69	4.92	0.96	2.48	6.66	6.78	6.91	0.81	
4.125	8.99	5.13	5.81	5.04	0.96	2.48	6.79	6.90	7.03	0.81	
4.250	8.99	5.25	5.94	5.17	0.96	2.48	6.92	7.17	7.26	0.81	
4.375	9.34	5.38	6.06	5.29	0.96	2.48	7.03	7.15	7.28	0.81	
4.500	9.49	5.50	6.19	5.42	0.96	2.48	7.18	7.30	7.43	0.81	
4.625	9.49	5.63	6.31	5.54	0.96	2.48	7.30	7.55	7.65	0.81	
4.750	10.49	5.75	6.47	5.67	0.96	2.48	7.41	7.66	7.75	0.81	

Chesterton ISO certificates available on [www.chesterton.com/corporate/iso](http://www.chesterton.com/corporate/iso)

Viewlin™ and AXIUS™ are trademarks of A.W. Chesterton Company. Technical data reflects results of laboratory tests and is intended to indicate general characteristics only. A.W. Chesterton Company disclaims all warranties express or implied, including warranties of merchantability and fitness for a particular purpose. Liability, if any, is limited to product replacement only. Any images contained herein are for general illustrative or aesthetic purposes only and are not intended to convey any instructional, safety, handling or usage information or advice respecting any product or equipment. Please refer to relevant Safety Data Sheets, Product Data Sheets, and/or Product Labels for safe use, storage, handling, and disposal of products, or consult with your local Chesterton sales representative.

© 2019 A.W. Chesterton Company  
 ®Registered trademark owned by A.W. Chesterton Company  
 in USA and other countries, unless otherwise noted.

Distributed by:



Sede legale: Via Panoramica 191 - 23010 Berbenno di Valtellina (SO)  
 Sede operativa: Via Europa angolo G. Marconi sn - 23010 Berbenno di Valtellina (SO)  
 C.F./P. IVA: 00877330142  
 Tel. 0342-492714  
 Mail: info@mkrit - Pec: mkr@peclegal.it



A.W. Chesterton Company  
 860 Salem Street  
 Groveland, MA 01834 USA

Telephone: 781-438-7000  
 Fax: 978-469-6528  
[chesterton.com](http://chesterton.com)

Form No. EN50030  
 1810 Product Data Sheet – English  
 03/19