

2810

Heavy-Duty Modular Double Cartridge Seal

Built on Chesterton's AXIUS™ modular platform for simple configuration and emission control plant-wide

This Chesterton® double cartridge seal offers you the ultimate in seal quality, flexibility, and emissions control. Leveraging Chesterton's proprietary AXIUS modular platform, the 2810 can be configured with several different face profiles and auxiliary components within a common gland housing. This flexibility allows seal performance to be tailored to a wide range of process conditions.

A plant-wide sealing solution, the 2810 uses a geometric double-balanced seal face design. An optimized barrier/buffer channel for enhanced fluid flow provides greater seal reliability even at elevated temperatures.



Advantages

- Simplifies configuration and maximizes seal performance with the AXIUS™ modular platform
- Maintains reliability throughout temperature cycling and stop/start processes with monolithic seal faces
- Increases face life and reduces contact stress with cushioned drive pins
- Accommodates axial, radial, and angular shaft movement through unified seal face alignment
- Allows for easy, positive seal identification with ViewIn™ technology

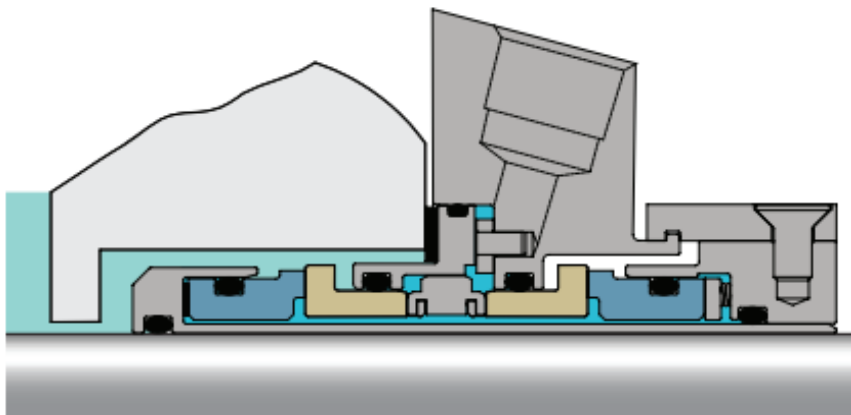

SPECIFICATIONS

Operating Parameters

Sizes	25 mm – 120 mm 1.00" – 4.75"
Pressure	711 mm or 28" Hg Vacuum to 40 bar g (600 psig*) 17 bar g (250 psig) outboard
Temperature	-55°C – 300°C (-67°F – 570°F) Temperature limits depend on actual elastomers used
Speed	25 m/s (5000 fpm)

Applicable Standards and Approvals

ISO-3069C, ASME B73.1, B73.2, ATEX Category I, Group 2 approved

* Seal pressure capabilities are dependent on the fluid sealed, temperature, speed, and seal face combinations. For operation outside the limits and additional materials consult Chesterton Mechanical Seal Engineering.

Materials of Construction

Rotary Faces	CB SSC TC
Stationary Faces	SSC TC
Elastomers	FKM EPDM FEPM FFKM
Metal Parts	316 Stainless Steel (EN 1.4401)
Springs	Alloy C-276 (EN 2.4819)

Dimensional Data

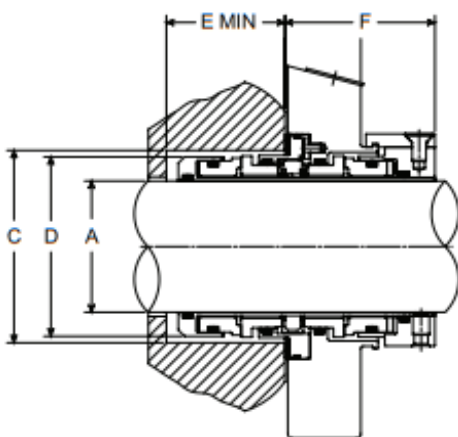
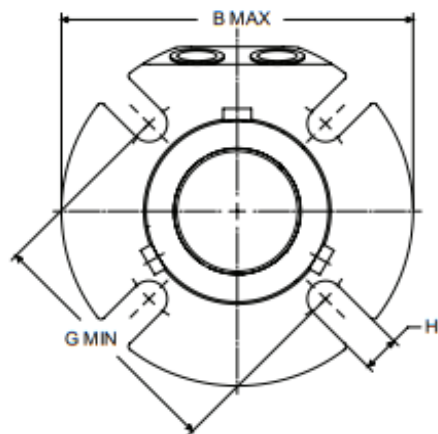

2810 KEY

- A - Shaft Size
- B - Maximum Gland Diameter
- C - Seal Chamber Bore
- D - Seal Outside Diameter
- E - Minimum Seal Chamber Depth
- F - Outboard Seal Length
- G - Minimum Bolt Circle by Bolt Size
- H - Slot Width

2810 Dimensional Data Metric

SHAFT SIZE	GLAND OD	STUFFING BOX BORE		IB SEAL DIA	SB DEPTH	OB LENGTH	BOLT CIRCLE BY BOLT SIZE			SLOT WIDTH
		B	C				C	G MIN		
A	B	MIN	MAX	D	E	F	10 mm	12 mm	16 mm	H
25	104	44	54	43	40	54	73	-	-	11
28	104	47	57	46	40	54	76	-	-	11
30	104	49	59	48	40	54	78	-	-	11
32	104	51	61	50	40	54	80	-	-	11
33	114	52	62	51	40	54	81	83	-	14
35	111	54	64	53	40	54	85	85	-	14
38	114	57	66	56	40	54	86	88	-	14
40	127	59	68	58	40	54	90	92	-	13
42	127	61	68	60	40	54	89	92	-	13
43	127	62	68	61	40	54	94	96	-	13
45	139	64	73	63	40	54	95	97	-	13
48	139	67	73	66	40	54	95	97	-	13
50	139	69	78	68	40	54	100	102	-	13
53	152	73	87	72	40	54	109	111	115	17
55	152	74	83	73	40	54	105	107	119	17
58	152	80	91	78	40	54	116	118	122	17
60	152	80	91	78	40	54	116	118	130	17
65	164	86	101	84	40	54	-	128	132	17
70	196	96	113	93	52	64	137	141	-	17
75	202	102	119	99	52	64	143	147	-	17
80	203	106	122	103	52	64	149	151	-	17
85	211	111	129	109	52	64	156	159	163	21
90	214	116	132	113	52	64	160	164	168	21
95	221	121	138	118	52	64	161	156	169	21
100	228	127	144	125	52	64	168	172	176	21
110	237	137	154	134	52	64	178	182	186	21
120	266	146	163	144	52	64	190	194	197	21

2810 Dimensional Data Inches

SHAFT SIZE	GLAND OD	STUFFING BOX BORE		IB SEAL DIA	SB DEPTH	OB LENGTH	BOLT CIRCLE BY BOLT SIZE			SLOT WIDTH
		B	C				C	G MIN		
A	B	MIN	MAX	D	E	F	3/8"	1/2"	5/8"	H
1.000	4.11	1.75	2.13	1.69	1.58	2.13	2.87	-	-	0.44
1.125	4.11	1.88	2.26	1.82	1.58	2.13	3.00	-	-	0.44
1.250	4.11	2.00	2.38	1.94	1.58	2.13	3.12	-	-	0.44
1.375	4.36	2.13	2.51	2.07	1.58	2.13	3.25	3.37	-	0.57
1.500	4.49	2.25	2.63	2.19	1.58	2.13	3.38	3.50	-	0.57
1.625	4.99	2.38	2.69	2.32	1.58	2.13	3.51	3.63	-	0.57
1.750	5.49	2.50	2.81	2.44	1.58	2.13	3.62	3.75	-	0.57
1.875	5.49	2.63	2.94	2.57	1.58	2.13	3.75	3.87	-	0.57
2.000	5.49	2.75	3.19	2.69	1.58	2.13	4.13	4.25	-	0.57
2.125	5.99	2.88	3.44	2.81	1.58	2.13	4.25	4.38	4.50	0.69
2.250	5.99	3.00	3.56	2.94	1.58	2.13	4.37	4.50	4.62	0.69
2.375	5.99	3.13	3.59	3.07	1.58	2.13	4.58	4.71	4.83	0.69
2.500	6.49	3.25	3.81	3.19	1.58	2.13	4.62	4.75	4.87	0.69
2.625	6.49	3.38	3.94	3.32	1.58	2.13	5.00	5.12	5.25	0.69
2.750	7.71	3.75	4.44	3.67	2.05	2.50	5.42	5.55	-	0.69
2.875	7.83	3.88	4.56	3.79	2.05	2.50	5.50	5.71	-	0.69
3.000	7.94	4.00	4.69	3.92	2.05	2.50	5.65	5.77	-	0.69
3.125	7.99	4.13	4.81	4.04	2.05	2.50	5.80	5.92	-	0.69
3.250	8.19	4.25	4.94	4.17	2.05	2.50	5.93	6.17	-	0.69
3.375	8.31	4.38	5.06	4.29	2.05	2.50	6.05	6.30	6.39	0.81
3.500	8.44	4.50	5.19	4.42	2.05	2.50	6.18	6.31	6.43	0.81
3.625	8.49	4.63	5.31	4.54	2.05	2.50	6.31	6.52	6.62	0.81
3.750	8.72	4.75	5.44	4.67	2.05	2.50	6.38	6.51	6.63	0.81
3.875	8.84	4.88	5.56	4.79	2.05	2.50	6.52	6.72	6.82	0.81
4.000	8.96	5.00	5.69	4.92	2.05	2.50	6.66	6.78	6.91	0.81
4.125	8.99	5.13	5.81	5.04	2.05	2.50	6.79	6.90	7.03	0.81
4.250	8.99	5.25	5.94	5.17	2.05	2.50	6.92	7.17	7.26	0.81
4.375	9.34	5.38	6.06	5.29	2.05	2.50	7.03	7.15	7.28	0.81
4.500	9.49	5.50	6.19	5.42	2.05	2.50	7.18	7.30	7.43	0.81
4.625	9.49	5.63	6.31	5.54	2.05	2.50	7.30	7.55	7.65	0.81
4.750	10.49	5.75	6.47	5.67	2.05	2.50	7.41	7.66	7.75	0.81

Chesterton ISO certificates available on www.chesterton.com/corporate/iso

ViewIn™ and AXIUS™ are trademarks of A.W. Chesterton Company. Technical data reflects results of laboratory tests and is intended to indicate general characteristics only. A.W. Chesterton Company disclaims all warranties express or implied, including warranties of merchantability and fitness for a particular purpose. Liability, if any, is limited to product replacement only. Any images contained herein are for general illustrative or aesthetic purposes only and are not intended to convey any instructional, safety, handling or usage information or advice respecting any product or equipment. Please refer to relevant Safety Data Sheets, Product Data Sheets, and/or Product Labels for safe use, storage, handling, and disposal of products, or consult with your local Chesterton sales representative.

© 2019 A.W. Chesterton Company
 Registered trademark owned by A.W. Chesterton Company in USA and other countries unless otherwise noted.

Distributed by:



Sede legale: Via Panoramica 191 - 23010 Berbenno di Valtellina (SO)
 Sede operativa: Via Europa angolo G. Marconi sn - 23010 Berbenno di Valtellina (SO)
 C.F./P. IVA: 00877330142
 Tel: 0342-492714
 Mail: info@mk.it - Pec: mk@mkclegal.it



A.W. Chesterton Company
 860 Salem Street
 Groveland, MA 01834 USA

Telephone: 781-438-7000
 Fax: 978-469-6528
chesterton.com

Form No. EN50029
 2810 Product Data Sheet - English
 06/19